

HAITIAN INTERNATIONAL HOLDINGS LIMITED
Unit 1105 Level 11
Metroplaza Tower 2
223 Hing Fong RD Kwai Fong N.T
haitian@mail.haitian.com
www.haitian.com

NINGBO HAITIAN HUAYUAN MACHINERY CO., LTD.
Export Processing Zone, Ningbo 315800 China
+86-574-86177242
+86-574-86221864
haitian@mail.haitian.com
www.haitian.com

Haitian **Mars²** Series
Specifications / International
600-10000KN

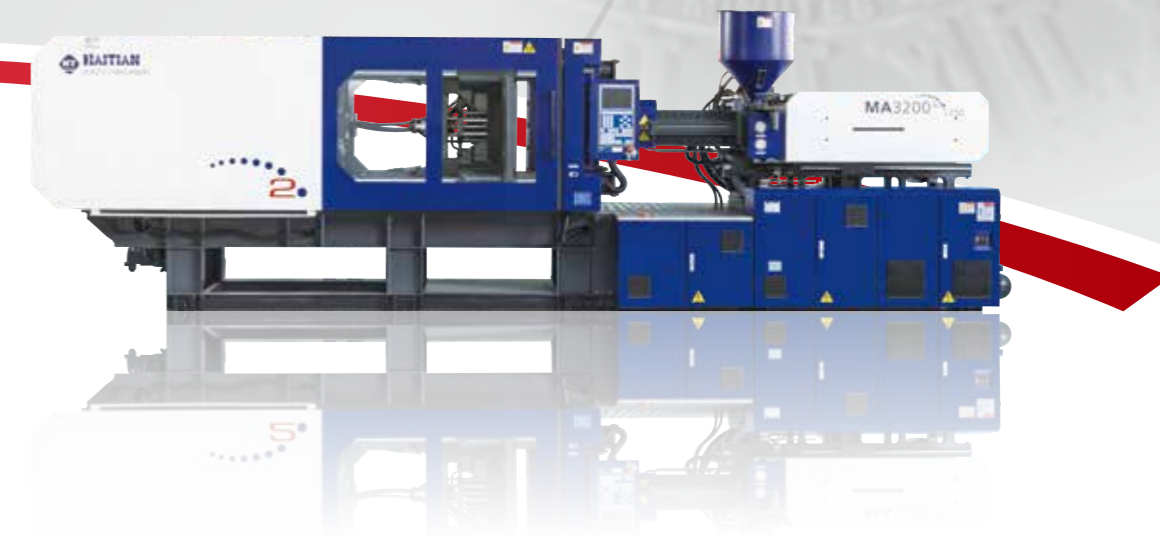

Haitian Partner:

HT 20170308-IV

Specification

		MA600 /130			MA900 /300			MA1200 /410			MA1600 /600			MA2000 /770			MA2500 /1000		
		A	B		A	B	C	A	B	C	A	B	C	A	B	C	A	B	C
INJECTION UNIT																			
Screw diameter	mm	24	28		32	36	40	36	40	45	40	45	50	45	50	55	50	55	60
Screw L/D ratio	L/D	23.3	20		22.5	20	18	23.3	21	18.7	22.5	20	18	22.2	20	18.2	22	20	18.3
Shot size (theoretical)	cm ³	50	68		121	153	188	173	214	270	253	320	395	334	412	499	471	570	679
Injection weight (PS)	g	46	62		110	139	171	157	195	246	230	291	359	304	375	454	429	519	618
Injection rate (PS)	g/s	57	78		85	108	133	112	139	176	131	165	204	160	198	239	216	261	311
Injection pressure	MPa	243	179		249	196	159	236	192	151	238	188	152	231	187	154	215	178	149
Plasticizing rate (PS)	g/s	6	8.6		12.7	16.8	20.3	17.6	21.3	28.4	21.2	28.1	35.3	25.7	32.2	39.4	36	44.1	52.2
Screw speed	rpm	0-310			0-290			0-270			0-255			0-195			0-235		
CLAMPING UNIT																			
Clamp tonnage	kN	600			900			1200			1600			2000			2500		
Toggle stroke	mm	270			320			360			430			490			540		
Space between tie bars	mm	310×310			360×360			410×410			470×470			530×530			580×580		
Max. mold height	mm	330			380			450			520			550			580		
Min. mold height	mm	120			150			150			180			200			220		
Ejector stroke	mm	70			100			120			140			140			150		
Ejector force	kN	22			33			33			33			62			62		
OTHERS																			
Max. pump pressure	MPa	16			16			16			16			16			16		
Pump motor power	kW	11			13			15			18.5			22			30		
Heater power	kW	5.2			6.3			9.95			9.95			16.95			17.8		
Machine dimension (l x w x h)	m	3.75×1.05×1.87			4.4×1.13×1.91			4.88×1.20×2.03			5.4×1.30×2.08			5.9×1.43×2.16			6.42×1.48×2.18		
Machine weight	t	2.5			3.5			4.35			5.65			7.1			8.4		
Hopper capacity	kg	25			25			25			25			50			50		
Oil tank capacity	l	170			190			255			300			350			455		

Platen dimensions
Moving platen

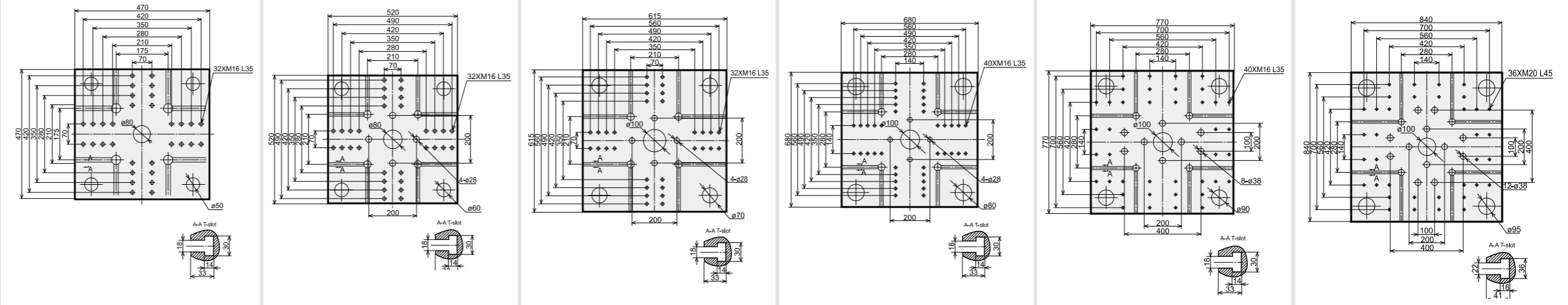

Platen dimensions
Mounting hole for robot/sprue picker top view from fixed platen

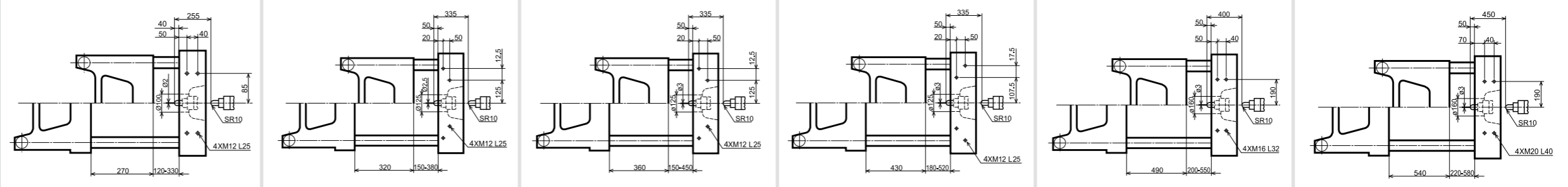

Machine dimensions

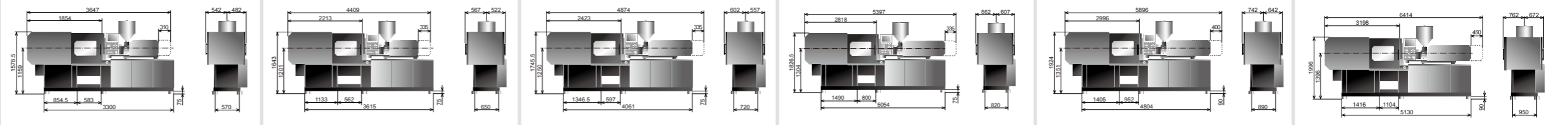

We reserve the right to make changes as a result of further technical advantages.

Specification

		MA2800 /1350			MA3200 /1700			MA3800 /2250				MA4700 /2950				MA5300 /4500			
		A	B	C	A	B	C	A	B	C	D	A	B	C	D	A	B	C	D
INJECTION UNIT																			
Screw diameter	mm	55	60	65	60	65	70	65	70	75	80	70	80	84	90	80	85	90	100
Screw L/D ratio	L/D	21.8	20	18.5	21.7	20	18.6	21.5	20	18.7	17.5	22.9	20	19.1	17.8	22	20.7	19.6	17.6
Shot size (theoretical)	cm ³	618	735	863	792	929	1078	1068	1239	1423	1619	1424	1860	2050	2354	2212	2497	2799	3456
Injection weight (PS)	g	562	669	785	721	845	981	972	1127	1295	1473	1296	1693	1866	2142	2013	2272	2547	3145
Injection rate (PS)	g/s	265	316	370	299	351	407	333	386	443	504	381	498	549	630	504	569	638	788
Injection pressure	MPa	219	184	157	213	182	157	211	182	158	139	207	158	143	125	201	178	159	129
Plasticizing rate (PS)	g/s	47.7	56.6	62.9	53.4	59.2	67.2	58.6	67.3	76.1	84.4	64.7	76.8	84.3	95.3	64.7	71.5	81.4	99.5
Screw speed	rpm	0-265			0-235			0-220				0-180				0-160			
CLAMPING UNIT																			
Clamp tonnage	kN	2800			3200			3800				4700				5300			
Toggle stroke	mm	590			640			700				780				850			
Space between tie bars	mm	630×630			680×680			730×730				820×800				840×830			
Max. mold height	mm	630			680			730				780				850			
Min. mold height	mm	230			250			280				320				350			
Ejector stroke	mm	150			160			180				200				220			
Ejector force	kN	62			62			110				110				158			
OTHERS																			
Max. pump pressure	MPa	16			16			16				16				16			
Pump motor power	kW	37			37			45				55				55			
Heater power	kW	23.4			27			33				38.95				47.95			
Machine dimension (l x w x h)	m	6.7×1.64×2.35			7.13×1.7×2.35			7.49×1.81×2.35				8.2×2.0×3.1				9.3×2.0×3.5			
Machine weight	t	11			13.2			15				19				26			
Hopper capacity	kg	50			50			50				100				200			
Oil tank capacity	l	580			690			690				830				940			

Platen dimensions
Moving platen

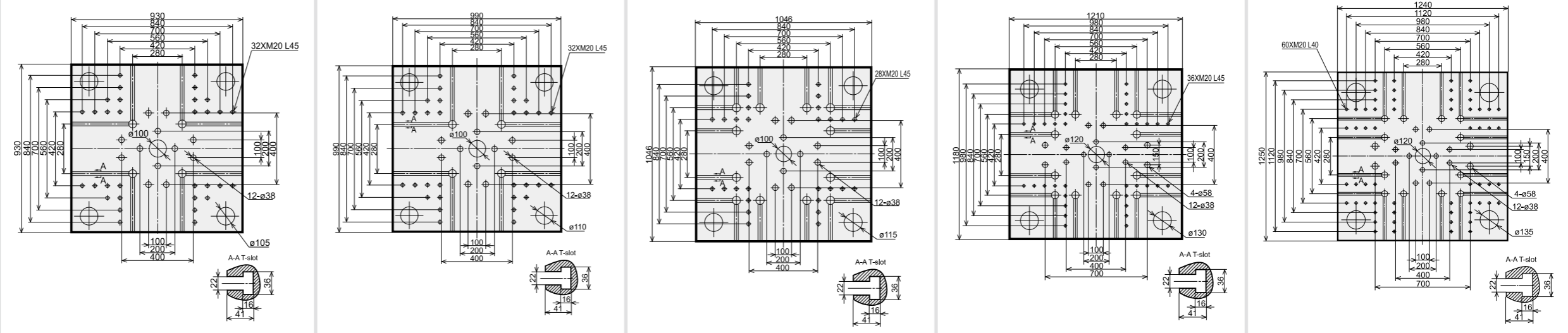

Platen dimensions
Mounting hole for robot/sprue picker top view from fixed platen

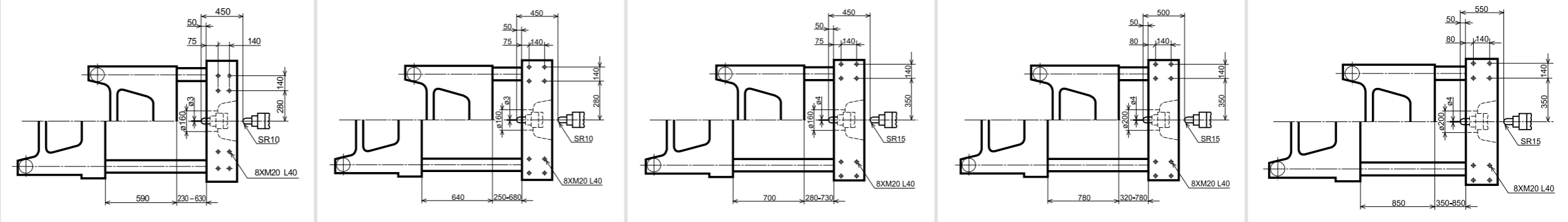

Machine dimensions

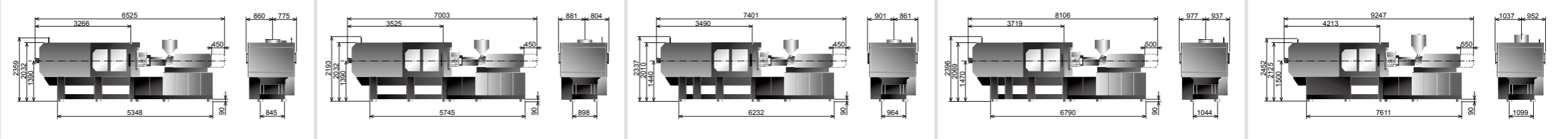

We reserve the right to make changes as a result of further technical advantages.

Specification

		MA6000 /4500				MA7000 /5000				MA8000 /6800				MA9000 /6800				MA10000 /8400			
		A	B	C	D	A	B	C	D	A	B	C	D	A	B	C	D	A	B	C	D
INJECTION UNIT																					
Screw diameter	mm	80	85	90	100	80	90	100	110	90	100	110	120	90	100	110	120	100	110	120	130
Screw L/D ratio	L/D	22	20.7	19.6	17.6	24.8	22	19.8	18	24.4	22	20	18.3	24.4	22	20	18.3	24.2	22	20.2	18.6
Shot size (theoretical)	cm ³	2212	2497	2799	3456	2262	2863	3534	4276	2990	3691	4467	5316	2990	3691	4467	5316	4006	4847	5768	6769
Injection weight (PS)	g	2013	2272	2547	3145	2058	2605	3216	3891	2721	3359	4065	4838	2721	3359	4065	4838	3645	4411	5249	6160
Injection rate (PS)	g/s	504	569	638	788	491	621	767	928	544	671	812	967	544	671	812	967	708	857	1019	1196
Injection pressure	MPa	201	178	159	129	224	177	143	118	228	184	152	128	228	184	152	128	211	174	146	125
Plasticizing rate (PS)	g/s	64.7	71.5	81.4	99.5	70.9	88.9	109	129	78.2	95.9	114	133	78.2	95.9	114	133	101	121	140	161
Screw speed	rpm	0-160				0-145				0-118				0-118				0-116			
CLAMPING UNIT																					
Clamp tonnage	kN	6000				7000				8000				9000				10000			
Toggle stroke	mm	900				970				1040				1120				1220			
Space between tie bars	mm	880x880				960x940				1000x1000				1080x1080				1160x1160			
Max. mold height	mm	880				940				1000				1080				1160			
Min. mold height	mm	380				400				420				450				500			
Ejector stroke	mm	240				260				280				300				320			
Ejector force	kN	158				186				186				186				215			
OTHERS																					
Max. pump pressure	MPa	16				16				16				16				16			
Pump motor power	kW	55				22+45				22+55				22+55				37+55			
Heater power	kW	47.95				54.25				70.6				70.6				83			
Machine dimension (l x w x h)	m	9.6x2.1x3.5				10.4x2.3x3.6				11.3x2.32x3.65				11.6x2.42x3.65				12.35x2.49x3.75			
Machine weight	t	29				32				38				45				51			
Hopper capacity	kg	200				200				200				200				200			
Oil tank capacity	l	940				1130				1280				1280				1480			

Platen dimensions
Moving platen

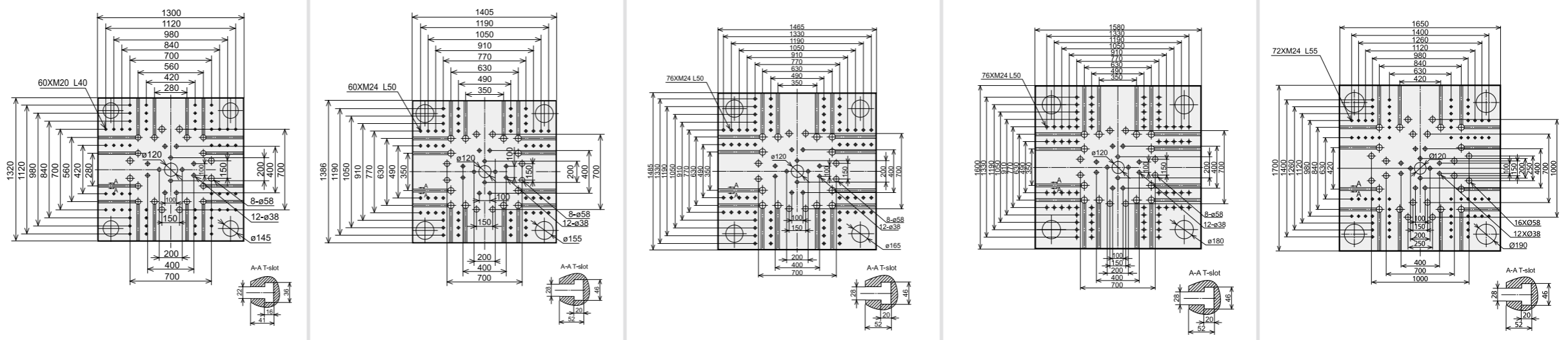

Platen dimensions
Mounting hole for robot/sprue picker top view from fixed platen

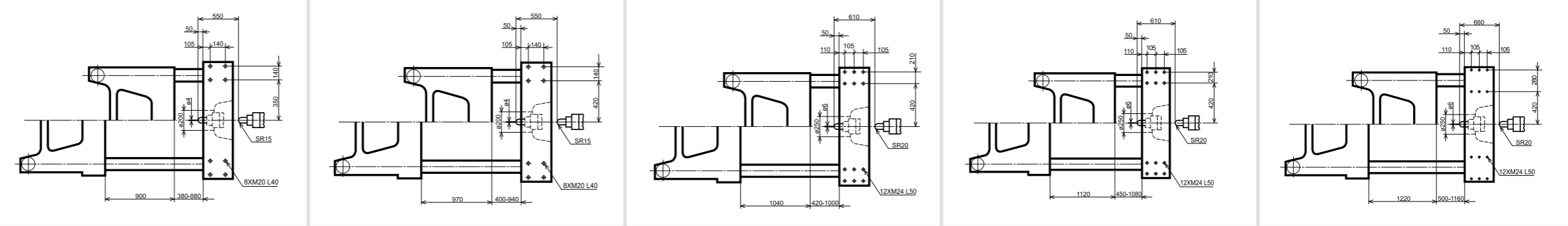

Machine dimensions

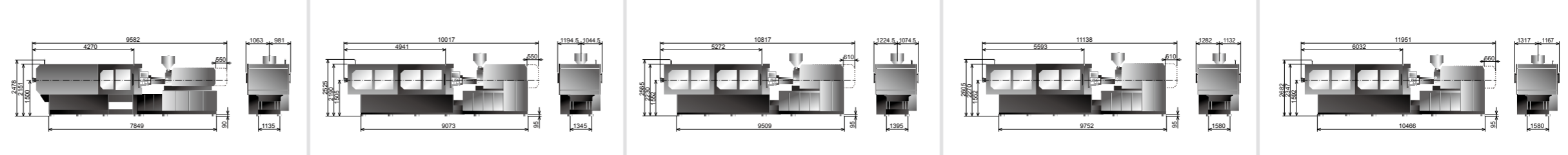

We reserve the right to make changes as a result of further technical advantages.